

***TPA0152***  
***Audio Power Amplifier***  
***Evaluation Module***

*User's Guide*

## IMPORTANT NOTICE

Texas Instruments and its subsidiaries (TI) reserve the right to make changes to their products or to discontinue any product or service without notice, and advise customers to obtain the latest version of relevant information to verify, before placing orders, that information being relied on is current and complete. All products are sold subject to the terms and conditions of sale supplied at the time of order acknowledgement, including those pertaining to warranty, patent infringement, and limitation of liability.

TI warrants performance of its semiconductor products to the specifications applicable at the time of sale in accordance with TI's standard warranty. Testing and other quality control techniques are utilized to the extent TI deems necessary to support this warranty. Specific testing of all parameters of each device is not necessarily performed, except those mandated by government requirements.

CERTAIN APPLICATIONS USING SEMICONDUCTOR PRODUCTS MAY INVOLVE POTENTIAL RISKS OF DEATH, PERSONAL INJURY, OR SEVERE PROPERTY OR ENVIRONMENTAL DAMAGE ("CRITICAL APPLICATIONS"). TI SEMICONDUCTOR PRODUCTS ARE NOT DESIGNED, AUTHORIZED, OR WARRANTED TO BE SUITABLE FOR USE IN LIFE-SUPPORT DEVICES OR SYSTEMS OR OTHER CRITICAL APPLICATIONS. INCLUSION OF TI PRODUCTS IN SUCH APPLICATIONS IS UNDERSTOOD TO BE FULLY AT THE CUSTOMER'S RISK.

In order to minimize risks associated with the customer's applications, adequate design and operating safeguards must be provided by the customer to minimize inherent or procedural hazards.

TI assumes no liability for applications assistance or customer product design. TI does not warrant or represent that any license, either express or implied, is granted under any patent right, copyright, mask work right, or other intellectual property right of TI covering or relating to any combination, machine, or process in which such semiconductor products or services might be or are used. TI's publication of information regarding any third party's products or services does not constitute TI's approval, warranty or endorsement thereof.

# Preface

---

---

---

---

## ***Related Documentation From Texas Instruments***

- ***TI Plug-N-Play Audio Amplifier Evaluation Platform*** (literature number SLOU011) provides detailed information on the evaluation platform and its use with TI audio evaluation modules.
- ***TPA0152 STEREO 2-W AUDIO POWER AMPLIFIER*** (literature number SLOS246) This is the data sheet for the TPA0152 audio amplifier integrated circuit.

## ***FCC Warning***

This equipment is intended for use in a laboratory test environment only. It generates, uses, and can radiate radio frequency energy and has not been tested for compliance with the limits of computing devices pursuant to subpart J of part 15 of FCC rules, which are designed to provide reasonable protection against radio frequency interference. Operation of this equipment in other environments may cause interference with radio communications, in which case the user at his own expense will be required to take whatever measures may be required to correct this interference.

## ***Trademarks***

TI is a trademark of Texas Instruments Incorporated.



# Contents

---

---

---

<b>1</b>	<b>Introduction</b>	<b>1-1</b>
1.1	Feature Highlights	1-2
1.2	Description	1-3
1.3	TPA0152 EVM Specifications	1-3
<b>2</b>	<b>Quick Start</b>	<b>2-1</b>
2.1	Precautions	2-2
2.2	Quick Start List for Platform	2-3
2.3	Quick Start List for Stand-Alone	2-5
<b>3</b>	<b>Details</b>	<b>3-1</b>
3.1	Precautions	3-2
3.2	The TPA0152 Audio Power Amplifier Evaluation Module	3-3
3.2.1	TPA0152 Audio Amplifier IC	3-4
3.2.2	Inputs and Gain	3-5
3.2.3	Differential Input	3-7
3.2.4	Depop Circuitry	3-7
3.2.5	BTL Operation	3-7
3.2.6	Single-Ended Operation	3-7
3.3	Using The TPA0152 EVM With the Plug-N-Play Evaluation Platform	3-8
3.3.1	Installing and Removing EVM Boards	3-8
3.3.2	TPA0152 Module Jumper Settings and Switches	3-9
3.3.3	Signal Routing	3-12
3.3.4	Mute (Shutdown)/Mode	3-13
3.3.5	Power Requirements	3-15
3.3.6	Inputs and Outputs	3-16
3.4	Using The TPA0152 EVM Stand-Alone	3-17
3.4.1	TPA0152 EVM Connected for BTL Output	3-17
3.4.2	TPA0152 EVM Connected for Single-Ended Output	3-18
3.5	TPA0152 Audio Power Amplifier Evaluation Module Parts List	3-19

# Figures

---

---

1-1	The TI TPA0152 Audio Amplifier Evaluation Module .....	1-3
2-1	Quick Start Platform Map .....	2-2
2-2	Module Preparation .....	2-4
2-3	Quick Start Module Map .....	2-5
3-1	The TI Plug-N-Play Audio Amplifier Evaluation Platform .....	3-2
3-2	TPA0152 EVM .....	3-3
3-3	TPA0152 EVM Schematic Diagram .....	3-4
3-4	TPA0152 Amplifier IC .....	3-5
3-5	TPA0152 EVM Jumpers and Switches .....	3-9
3-6	Platform Signal Routing and Outputs .....	3-12
3-7	Mute/Mode and Polarity Control .....	3-13
3-8	Typical Headphone Plug .....	3-16
3-9	TPA0152 EVM Connected for Stereo BTL Output .....	3-17
3-10	TPA0152 EVM Connected for Stereo Single-Ended Output .....	3-18

# Tables

---

---

2-1	Typical TI Plug-N-Play Platform Jumper and Switch Settings for the TPA0152 .....	2-1
2-2	Typical TPA0152 EVM Jumper Settings .....	2-1
2-3	Platform Jumper and Switch Settings for the TPA0152 .....	2-3
2-4	Typical TPA0152 EVM Jumper Settings .....	2-4
3-1	TPA0152 EVM Gain Settings .....	3-6
3-2	Typical TPA0152 EVM Jumper Settings for BTL Stand-Alone .....	3-17
3-3	Typical TPA0152 EVM Jumper Settings for Single-Ended Stand-Alone .....	3-18
3-4	TPA0152 EVM Parts List .....	3-19

# Introduction

---

---

---

---

This chapter provides an overview of the Texas Instruments (TI™) TPA0152 audio amplifier evaluation module (SLOP209). It includes a list of EVM features, a brief description of the module illustrated with a pictorial diagram, and a list of EVM specifications.

<b>Topic</b>	<b>Page</b>
<b>1.1 Feature Highlights</b> .....	<b>1-2</b>
<b>1.2 Description</b> .....	<b>1-3</b>
<b>1.3 TPA0152 EVM Specifications</b> .....	<b>1-3</b>

## 1.1 Feature Highlights

The TI TPA0152 audio amplifier evaluation module and the TI plug-n-play audio amplifier evaluation platform include the following features:

- TPA0152 Stereo 2-W Audio Power Amplifier Evaluation Module
  - Internal depop circuitry to minimize transients in outputs
  - Powers up at mute volume level to avoid pop
  - Dual channel, bridge-tied load (BTL) or single-ended operation
  - 2 W per channel output power into 3  $\Omega$  at 5 V, BTL
  - Low current consumption in shutdown mode (150  $\mu$ A)
  - Internal input MUX selects among two sets of stereo inputs
  - Digital volume control from +20 dB to –40 dB
  - Microprocessor mode volume control
  - Differential stereo inputs
  - PC Beep input
  
- Quick and Easy Configuration With The TI Plug-N-Play Audio Amplifier Evaluation Platform
  - Evaluation module is designed to simply plug into the platform, automatically making all signal, control, and power connections
  - Platform provides flexible power options
  - Jumpers on the platform select power and module control options
  - Switches on the platform route signals
  - Platform provides quick and easy audio input and output connections
  
- Platform Power Options
  - External 5-V – 15-V DC  $V_{CC}$  supply inputs
  - External regulated  $V_{DD}$  supply input
  - Socket for on-board 5 V/3.3 V  $V_{DD}$  voltage regulator EVM
  - Onboard overvoltage and reverse polarity power protection
  
- Platform Audio Input and Output Connections
  - Left and right RCA phono jack inputs
  - Miniature stereo phone jack input
  - Left and right RCA phono jack outputs
  - Left and right compression speaker terminal outputs
  - Miniature stereo headphone jack output



## 1.2 Description

The TPA0152 stereo 2-W audio power amplifier evaluation module is a complete, 2-Watt per channel stereo audio power amplifier. It consists of the TI TPA0152 stereo 2-W audio power amplifier IC along with a small number of other parts mounted on a circuit board that measures approximately 2¼ inches by 1½ inches (Figure 1–1).

Figure 1–1. The TI TPA0152 Audio Amplifier Evaluation Module

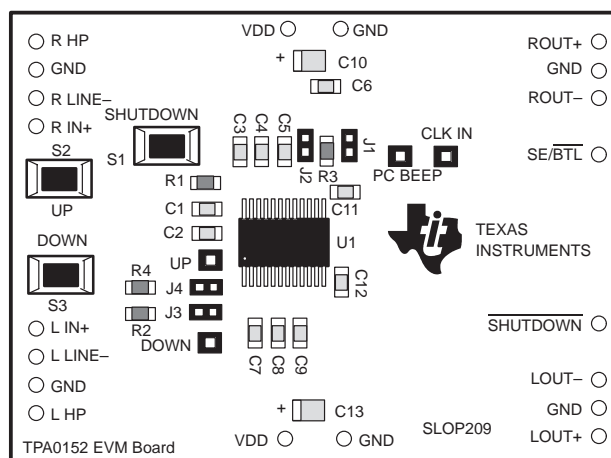

Single in-line header pins extend from the underside of the module circuit board to allow the EVM to be plugged into the TI plug-n-play audio amplifier evaluation platform, or to be wired directly into existing circuits and equipment when used stand-alone.

The platform has room for a single TPA0152 evaluation module and is a convenient vehicle for demonstrating TI's audio power amplifier and related evaluation modules. The EVMs simply plug into the platform, which automatically provides power to the modules, interconnects them correctly, and connects them to a versatile array of standard audio input and output jacks and connectors. Easy-to-use configuration controls allow the platform and EVMs to quickly model many possible end-equipment configurations.

There is nothing to build, nothing to solder, and nothing but the speakers included with the platform to hook up.

## 1.3 TPA0152 EVM Specifications

Supply voltage range, $V_{DD}$	4.5 V to 5.5 V
Supply current, $I_{DD}$	2 A max
Continuous output power per channel, $P_O$ : 3- $\Omega$ BTL, $V_{DD}=5$ V	2 W
Audio input voltage, $V_{I_1}$ : HP input	5 Vpp max
Line input	5 Vpp max
PC Beep input	5 Vpp max
Minimum load impedance, $R_L$	3 $\Omega$



## Quick Start

The steps in this chapter can be followed to quickly prepare the TPA0152 audio amplifier EVM for use. Using the TPA0152 with the TI plug-n-play audio amplifier evaluation platform is a quick and easy way to connect power, signal and control inputs, and signal outputs to the EVM using standard connectors. However, the audio amplifier evaluation module can be used stand-alone by making connections directly to the module pins, and can be wired directly into existing circuits or equipment.

The platform switch and jumper settings shown in Table 2–1 are typical for the TPA0152 EVM and will cause the TPA0152 to switch to single-ended output mode when a plug is inserted into platform headphone jack J10.

*Table 2–1. Typical TI Plug-N-Play Platform Jumper and Switch Settings for the TPA0152*

EVM	JP6	JP7	JP8	S2	S3
P-N-P Platform	Mode	X	Hi	Note 2	U2–U4

- Notes:**
- 1) X = Don't care
  - 2) Set S2 to ON when signal conditioning board is installed in U1; set S2 to OFF when no signal conditioning board is installed.

*Table 2–2. Typical TPA0152 EVM Jumper Settings*

EVM	J1	J2	J3	J4
TPA0152	OFF	ON	ON	ON

- Note:** ON = Shunt installed  
OFF = Open

Topic	Page
2.1 Precautions .....	2–2
2.2 Quick Start List for Platform .....	2–3
2.3 Quick Start List for Stand-Alone .....	2–5

## 2.1 Precautions

**Power Supply Input Polarity and Maximum Voltage**  
 Always ensure that the polarity and voltage of the external power connected to  $V_{CC}$  power input connector J1, J2, and/or  $V_{DD}$  power input connector J6 are correct. Overvoltage or reverse-polarity power applied to these terminals can open onboard soldered-in fuses and cause other damage to the platform, installed evaluation modules, and/or the power source.

**Inserting or Removing EVM Boards**  
 Do not insert or remove EVM boards with power applied — damage to the EVM board, the platform, or both may result.

Figure 2–1. Quick Start Platform Map

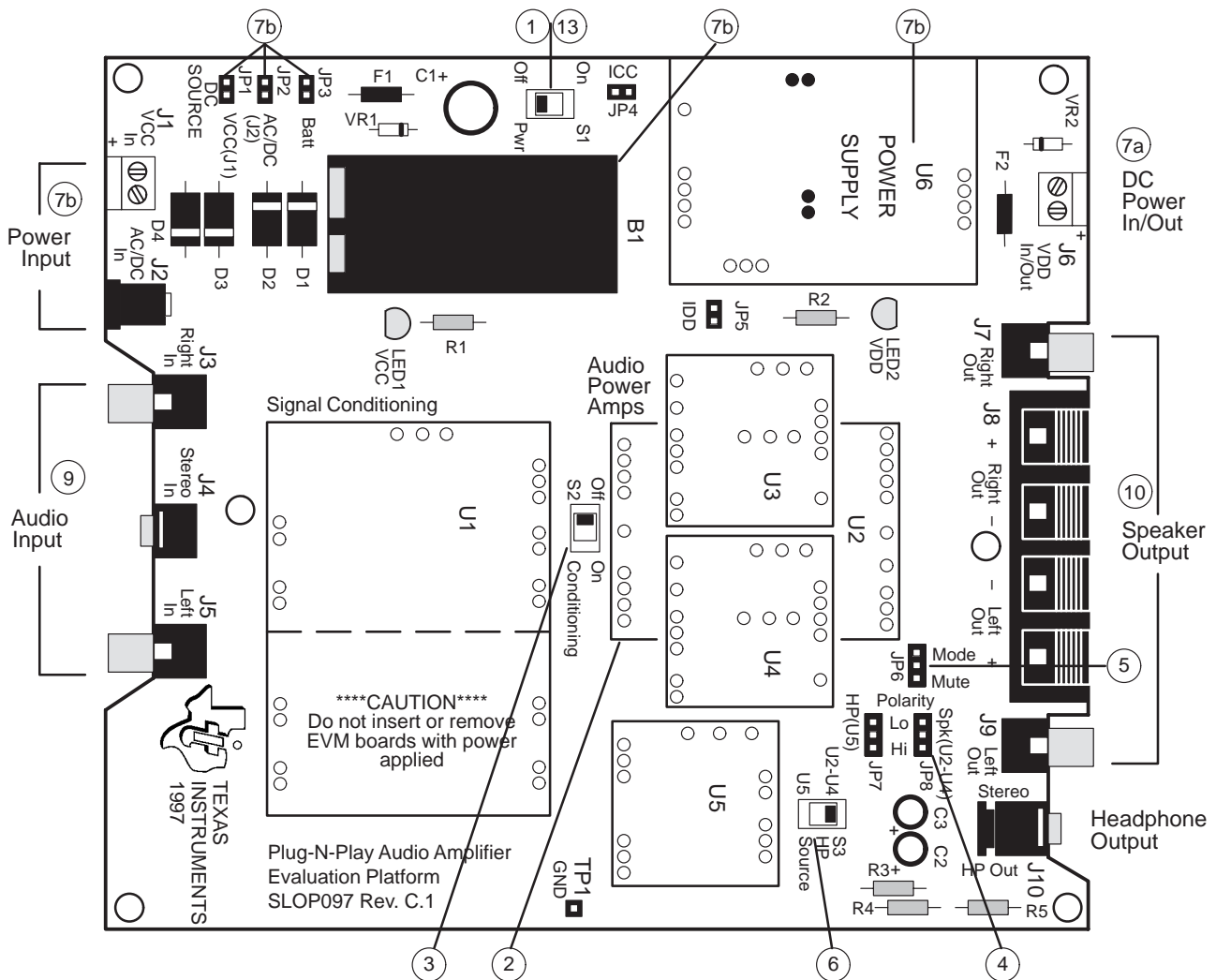

## 2.2 Quick Start List for Platform

Follow these steps when using the TPA0152 EVM with the TI plug-n-play audio amplifier evaluation platform (see the platform user's guide, SLOU011, for additional details). Numbered callouts for selected steps are shown in Figure 2–1 and Figure 2–2, and details appear in Chapter 3.

### Platform preparations

- 1) Ensure that all external power sources are set to **OFF** and that the platform power switch **S1** is set to **OFF**.
- 2) Install a TPA0152 module in platform socket **U2**, taking care to align the module pins correctly.
- 3) Use switch **S2** to select or bypass the signal conditioning EVM (**U1**).
- 4) Set control signal **Polarity** jumper **JP8** to **Hi**.
- 5) Set jumper **JP6** to select the **Mode** control input (causes the TPA0152 to switch to the single-ended output mode if a plug is inserted into platform headphone jack **J10**).
- 6) If the headphone Jack (**J10**) output will be used, set headphone source switch **S3** to **U2–U4**.

Table 2–3. Platform Jumper and Switch Settings for the TPA0152

EVM	JP6	JP7	JP8	S2	S3
P-N-P Platform	Mode	X	Hi	Note 2	U2–U4

**Notes:**

- 1) X = Don't care
- 2) Set **S2** to **ON** when signal conditioning board is installed in **U1**; set **S2** to **OFF** when no signal conditioning board is installed.

### Power supply

- 7) Select and connect the power supply (ensure power supply is set to **OFF**):
  - a) Connect an external regulated power supply set to 5 V to platform  $V_{DD}$  power input connector **J6** taking care to observe marked polarity, or
  - b) Install a voltage regulator EVM (SLVP097 or equiv.) in platform socket **U6**. Connect a 7 V – 12 V power source to a platform  $V_{CC}$  power input **J1** or **J2** and jumper the appropriate power input (see platform user's guide).

### Inputs and outputs

- 8) Ensure that the audio signal source level is set to minimum.
- 9) Connect the audio source to left and right RCA phono jacks **J3** and **J5** or stereo miniature phone jack **J4**.
- 10) Connect speakers to left and right RCA jacks **J7** and **J9** or to stripped wire speaker connectors **J8**.

**Evaluation Module Preparations**

Figure 2–2. Module Preparation

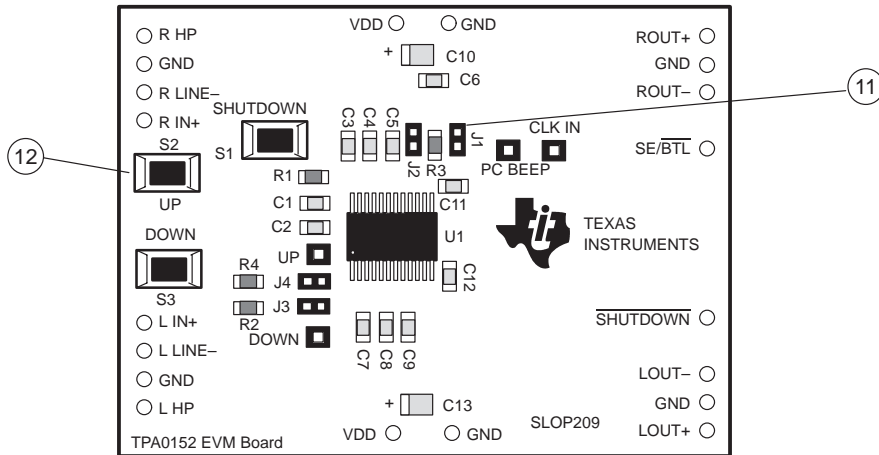

Table 2–4. Typical TPA0152 EVM Jumper Settings

EVM	J1	J2	J3	J4
TPA0152	OFF	ON	ON	ON

**Note:** ON = Shunt installed, OFF = Open

11) To allow the module SE/BTL control input to switch the amplifier IC between single ended (SE) and bridge-tied load (BTL) output modes, set output mode jumper **J1** to **OFF**. To keep the module amplifier IC in the single-ended output mode regardless of the control input state, set jumper **J1** to **ON**.

12) When the module powers up or comes out of shutdown, the volume is set at the –85 dB level. Press the **UP** pushbutton, **S2**, until the desired volume level is reached.

**Power Up**

13) Verify correct voltage and input polarity and set the external power supply to **ON**. If  $V_{CC}$  and an onboard regulator EVM are used to provide  $V_{DD}$ , set platform power switch **S1** to **ON**.

Platform LED2 should light indicating the presence of  $V_{DD}$ , and the evaluation modules installed on the platform should begin operation.

14) Adjust the signal source level as needed.

## 2.3 Quick Start List for Stand-Alone

Follow these steps to use the TPA0152 EVM stand-alone or when connecting it into existing circuits or equipment. Connections to the TPA0152 module header pins can be made via individual sockets, wire-wrapping, or soldering to the pins, either on the top or the bottom of the module circuit board. Numbered callouts for selected steps are shown in Figure 2–3 and details appear in Chapter 3.

Figure 2–3. Quick Start Module Map

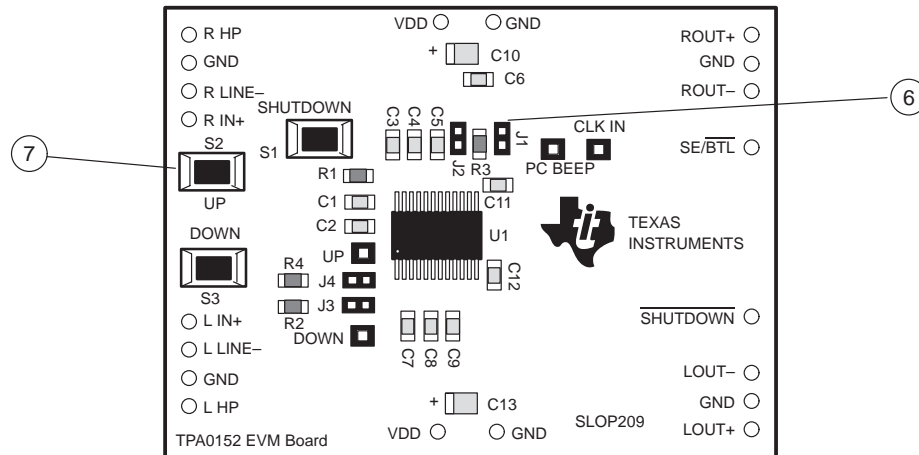

### Power supply

- 1) Ensure that all external power sources are set to **OFF**.
- 2) Connect an external regulated power supply set to 5 V to the module **VDD** and **GND** pins taking care to observe marked polarity.

### Inputs and outputs

- 3) Ensure that audio signal source level adjustments are set to minimum.
- 4) Connect the right (left) positive lead of the audio source to the module **R LINE–** (**L LINE–**) pins and the negative lead to the **R IN+** (**L IN+**) pins. If using the headphone inputs, connect the positive audio source to the module **R HP** (**L HP**) and the negative lead to **R IN+** (**L IN+**). The inputs can be used with a differential or single-ended audio source, but the headphone and line have common positive inputs.
- 5) Select output mode:
  - a) For BTL output, connect a speaker to the module **OUT+** and **OUT–** pins of each channel,  
or
  - b) For single-ended output, connect a headphone or a speaker to the module **OUT+** and **GND** pins of each channel through a 33  $\mu$ F to 1000  $\mu$ F output-coupling capacitor (Figure 3–10).

**Evaluation Module Preparations**

- 6) To allow the module  $\overline{\text{SE/BTL}}$  control input to switch the amplifier IC between single ended (SE) and bridge-tied load (BTL) output modes, set output mode jumper **J1** to **OFF**. To keep the module amplifier IC in the single-ended output mode regardless of the control input state, set jumper **J1** to **ON**.
- 7) When the module powers up or comes out of shutdown, the volume is set at the  $-85$  dB level. Press the **UP** pushbutton, **S2**, until the desired volume level is reached.

**Control Inputs**

- 8) Connect control lines to the various module control input pins as needed:
  - a)  $\overline{\text{SE/BTL}}$ : A high selects the single-ended (SE) output mode; a low or float selects the bridge-tied load (BTL) output mode.
  - b)  $\overline{\text{SHUTDOWN}}$ : A low shuts down the amplifier IC on the module; a high or float allows normal operation.

**Power Up**

- 9) Verify correct voltage and input polarity and set the external power supply to **ON**.

The EVM should begin operation.

- 10) Adjust the signal source level as needed.



# Details

---

---

---

---

---

This chapter provides details on the TPA0152 IC, the evaluation module, and the steps in the Quick-Start List, additional application information, and a parts list for the TPA0152 evaluation module.

<b>Topic</b>	<b>Page</b>
<b>3.1 Precautions</b> .....	<b>3-2</b>
<b>3.2 The TPA0152 Audio Power Amplifier Evaluation Module</b> .....	<b>3-3</b>
<b>3.3 Using the TPA0152 EVM With the Plug-N-Play Evaluation Platform</b> .....	<b>3-8</b>
<b>3.4 Using The TPA0152 EVM Stand-Alone</b> .....	<b>3-17</b>
<b>3.5 TPA0152 Audio Power Amplifier Evaluation Module Parts List</b> ..	<b>3-19</b>

### 3.1 Precautions

**Power Supply Input Polarity and Maximum Voltage**  
 Always ensure that the polarity and voltage of the external power connected to V<sub>CC</sub> power input connector J1, J2, and/or V<sub>DD</sub> power input connector J6 are correct. Overvoltage or reverse-polarity power applied to these terminals can open onboard soldered-in fuses and cause other damage to the platform, installed evaluation modules, and/or the power source.

**Inserting or Removing EVM Boards**  
 Do not insert or remove EVM boards with power applied — damage to the EVM board, the platform, or both may result.

Figure 3–1. The TI Plug-N-Play Audio Amplifier Evaluation Platform

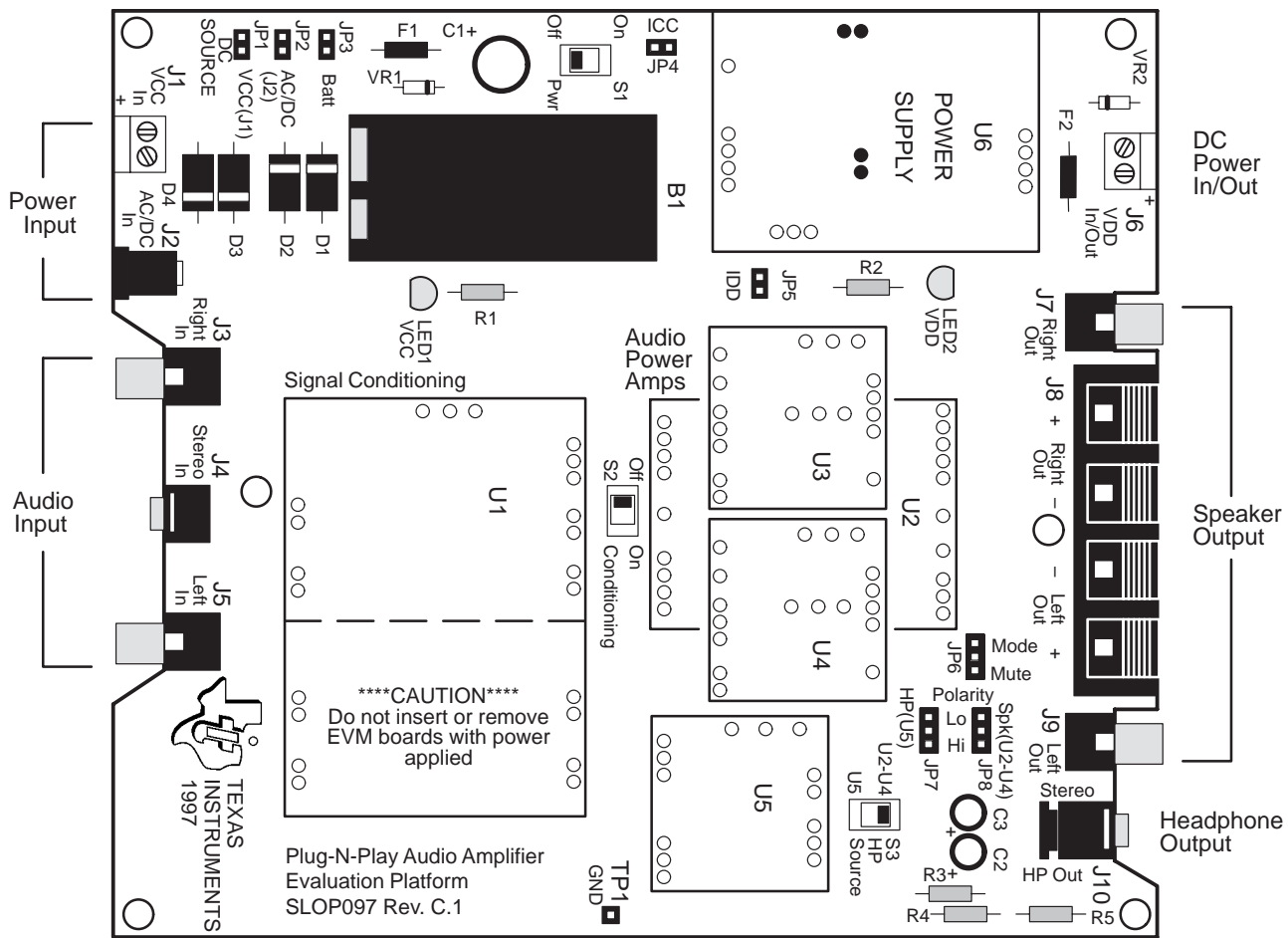

### 3.2 The TPA0152 Audio Power Amplifier Evaluation Module

The TPA0152 audio power amplifier evaluation module is powered by a TPA0152 stereo power amplifier capable of delivering greater than 2 W of continuous power per channel into 3-Ω loads. The amplifier IC can be operated in either the BTL or single-ended output mode. The evaluation module includes control inputs for shutdown, selection between two sets of stereo inputs, and switching between single-ended and bridge-tied load output modes.

The module can be used with the TI plug-n-play audio amplifier evaluation platform (Figure 3–1) or wired directly into circuits or equipment. The module has single in-line header connector pins mounted to the under side of the board. These pins allow the module to be plugged into the TI platform, which automatically makes all the signal input and output, power, and control connections to the module.

The module connection pins are on 0.1-inch centers to allow easy use with standard perf board and plug board-based prototyping systems. Or, the EVM can be wired directly into existing circuits and equipment when used stand-alone.

The module appears in Figure 3–2 and its schematic is shown in Figure 3–3.

Figure 3–2. TPA0152 EVM

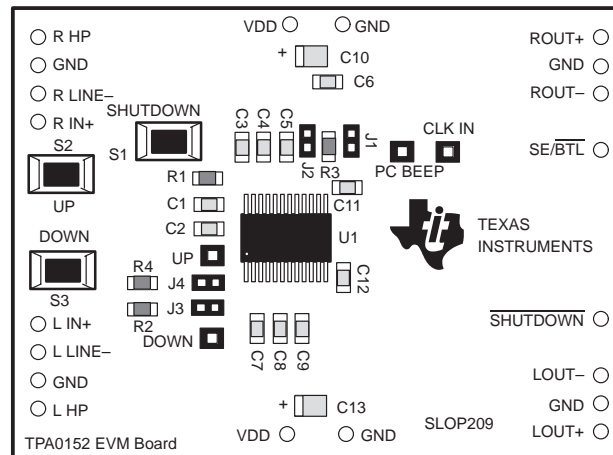
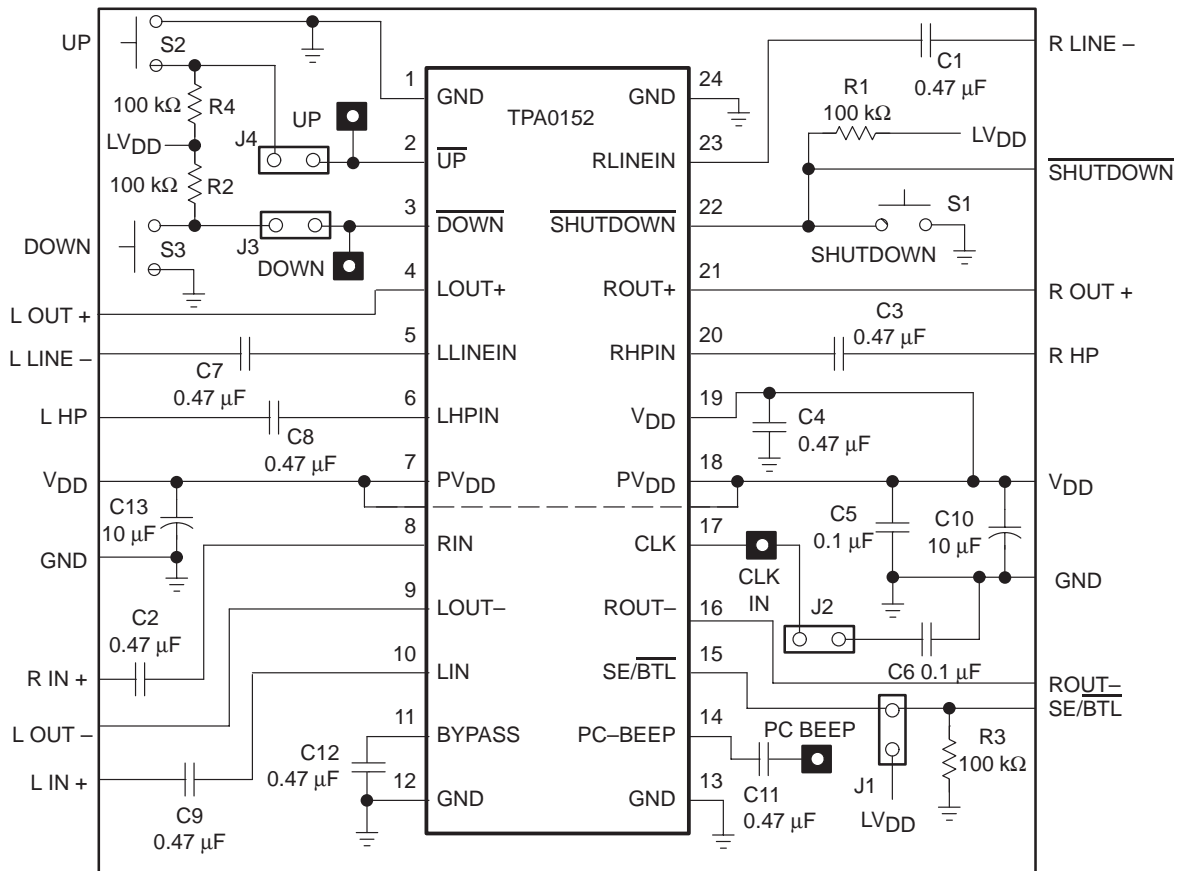

Figure 3–3. TPA0152 EVM Schematic Diagram



### 3.2.1 TPA0152 Audio Amplifier IC

The TPA0152 audio amplifier IC (Figure 3–4) is a CMOS device intended primarily for bridge-tied load (BTL) operation in battery-powered applications. It is supplied in a very small 24-pin TSSOP thermal surface-mount package and has been designed to operate from low supply voltages (between approximately 4.5 V and 5.5 V). Typical applications include portable computers and multimedia systems.

The IC includes two separate amplifier channels, each of which can operate in either the bridged-tied load (BTL) mode or the single-ended mode as selected by the SE/BTL pin. In the BTL mode, the line inputs are automatically selected and the two output lines of each channel operate as mirror images of each other for increased power. The speaker load is connected directly across OUT+ and OUT–, and neither line is connected to ground. BTL operation provides many benefits, including quadruple the output power of single-ended operation and no need for bulky output coupling capacitors.

In the single-ended mode, the headphone inputs are automatically selected and the speaker load is connected between the OUT+ terminal, through an output coupling capacitor, to system ground. For more information, see the TPA0152 amplifier IC data sheet, TI Literature Number SLOS246.

Figure 3–4. TPA0152 Amplifier IC

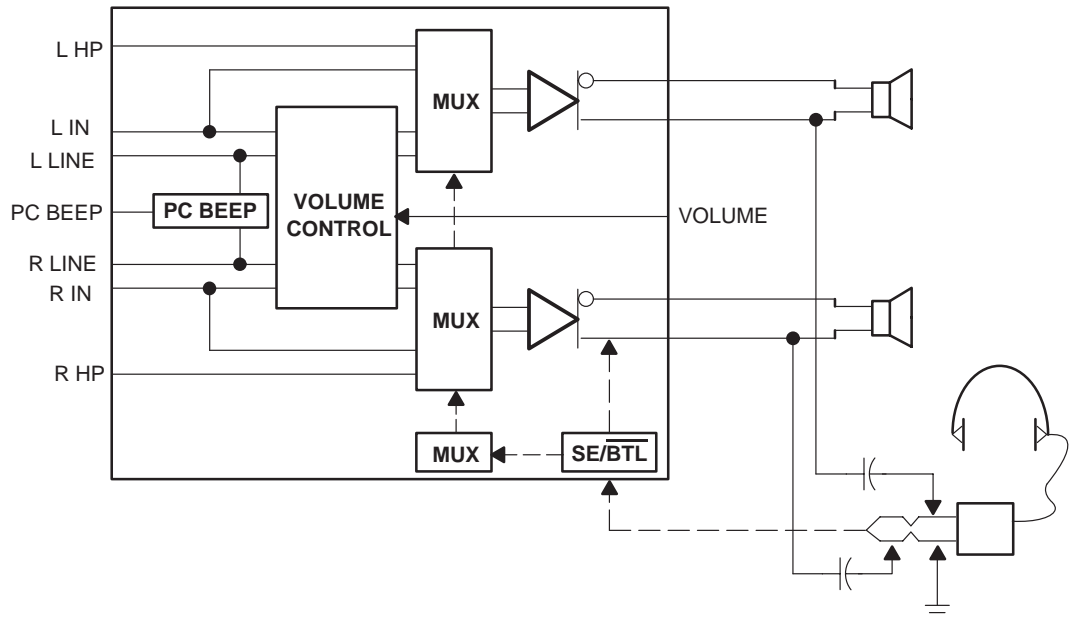

### 3.2.2 Inputs and Gain

Each channel has two separate signal inputs, *line* and *headphone (HP)*, that are automatically selected with the output mode (SE/BTL). An input multiplexer in the amplifier IC selects the HP inputs when the IC is in the SE output mode and the line inputs when in the BTL output mode.

Line and headphone inputs share common positive inputs. If using separate line and headphone inputs, R IN and L IN should be AC grounded through a capacitor. If using differential inputs, line and headphone inputs must be the same.

A third input, PC BEEP, is common to both channels. The TPA0152 IC monitors this input when operating in both the active and shutdown modes and automatically switches to this input when a signal is sensed. In computer applications, for example, this allows the normal audio signal (music, sounds, etc.) to be interrupted when there is a need to output a computer beep. When the beep signal ends, the IC switches back to the previous mode.

The PC BEEP input gain is approximately  $\frac{1}{4}$  V/V, and requires an input signal greater than 1 V peak-to-peak in order to detect the signal.

Pushbuttons S2 (**UP**) and S3 (**DOWN**) adjust the amount gain in the initial stage of the amplifier, which could be considered the preamplifier stage. As a result, the total harmonic distortion (THD) changes very little over all volume levels. At power up, this gain is set at the lowest level, -85 dB, or mute. Each time a button is pressed, the volume changes by one increment. If a button is held in the depressed position, the volume changes by one increment every four clock cycles, followed by a short delay. This delay decreases the longer the button is depressed, eventually reaching a delay of zero. Table 3-1 shows the volume control steps.

Table 3-1. TPA0152 EVM Gain Settings

VOLUME CONTROL (dB)	
20	
18	
16	
14	
12	
10	
8	
6	
4	
2	
0	
-2	
-4	
-6	
-8	
-10	
-12	
-14	
-16	
-18	
-20	
-22	
-24	
-26	
-28	
-30	
-32	
-34	
-36	
-38	
-40	
-85	MUTE (Initial/power up level)

### 3.2.3 Differential Input

The TPA0152 line inputs allow the use of a single-ended or differential audio source. The differential input stage of the amplifier cancels any noise that appears on both input lines of a channel. To use the TPA0152 EVM with a differential source, connect the positive lead of the audio source to the R LINE– (L LINE–) input and the negative lead from the audio source to the R IN+ (L IN+) input. To use the TPA0152 with a single-ended source, AC-ground the R IN+ and L IN+ inputs and apply the audio signal to the R LINE– and L LINE– inputs. Line and headphone inputs share common positive inputs. If using separate line and headphone inputs, R IN+ and L IN+ should be AC-grounded. If using differential inputs, line and headphone inputs must be the same. In a single-ended input application, the R IN+ and L IN+ inputs should be AC grounded at the audio source instead of at the device inputs for best noise performance.

### 3.2.4 Depop Circuitry

The TPA0152 amplifier IC contains internal circuitry to minimize the various transients that might appear at the output during the transition from power off or shutdown to normal operation, or when transitioning between the SE and BTL modes.

### 3.2.5 BTL Operation

To operate in the bridge-tied load output mode, the module  $\overline{\text{SE/BTL}}$  control input terminal must be held low. The module output signal from OUT+ must go through the speaker load and be returned directly to OUT–, and **NOT** to system ground. This requires that the OUT– line be isolated not only from system ground, but also from the OUT– lines of any other amplifiers in the system. The platform provides such isolated output lines from the amplifier EVM sockets directly to separate left and right speaker connectors.

### 3.2.6 Single-Ended Operation

For single-ended operation, the module  $\overline{\text{SE/BTL}}$  control input pin must be held high. The speaker (or headphone) load is connected to the module OUT+ output pin through a coupling capacitor, and to platform/system ground. A 470- $\mu\text{F}$  electrolytic coupling capacitor is provided on the platform in the signal path to the headphone output jack for this purpose, and a control signal from the platform headphone jack can be routed to the module control input pin to switch the TPA0152 IC to the single-ended mode.

In the single-ended mode, the amplifiers inside the TPA0152 IC that drive the OUT– lines do not operate and do not dissipate any power. The OUT– pins go into a high-impedance state and can be left connected or allowed to float.

### 3.3 Using The TPA0152 EVM With the Plug-N-Play Evaluation Platform

The TPA0152 audio amplifier evaluation module was designed to be used with the TI plug-n-play audio amplifier evaluation platform. It simply plugs into socket U2.

The following paragraphs provide additional details for using the TPA0152 EVM with the platform.

#### 3.3.1 Installing and Removing EVM Boards

TI plug-n-play evaluation modules use single-in-line header pins installed on the underside of the module circuit board to plug into sockets on the platform. The EVM pins and the platform sockets are keyed such that only the correct type of EVM can be installed in a particular socket, and then only with the proper orientation.

Evaluation modules are easily removed from the platform by simply prying them up and lifting them out of their sockets. Care must be taken, however, to prevent bending the pins.

##### 3.3.1.1 EVM Insertion

- 1) Remove all power from the evaluation platform.
- 2) Locate socket U2 on the platform.
- 3) Orient the module correctly.
- 4) Carefully align the pins of the module with the socket pin receptacles.
- 5) Gently press the module into place.
- 6) Check to be sure that all pins are seated properly and that none are bent over.

##### 3.3.1.2 EVM Removal

- 1) Remove all power from the evaluation platform.
- 2) Using an appropriate tool as a lever, gently pry up one side of the module a small amount.
- 3) Change to the opposite side of the module and use the tool to pry that side up a small amount.
- 4) Alternate between sides, prying the module up a little more each time to avoid bending the pins, until it comes loose from the socket.
- 5) Lift the EVM off of the platform.



### 3.3.2 TPA0152 Module Jumper Settings and Switches

The TPA0152 EVM is equipped with pushbutton SPST switches and jumpers that act as SPST switches to allow module operation to be modified to suit various requirements. In the following discussion, setting a jumper to **ON** means that a shunt is installed across the two pins of the jumper. Setting a jumper to **OFF** means that no shunt is installed on the jumper. See Figure 3.5.

In typical applications, some or all of the jumper functions are controlled by the system microcontroller or external logic.

Figure 3–5. TPA0152 EVM Jumpers and Switches

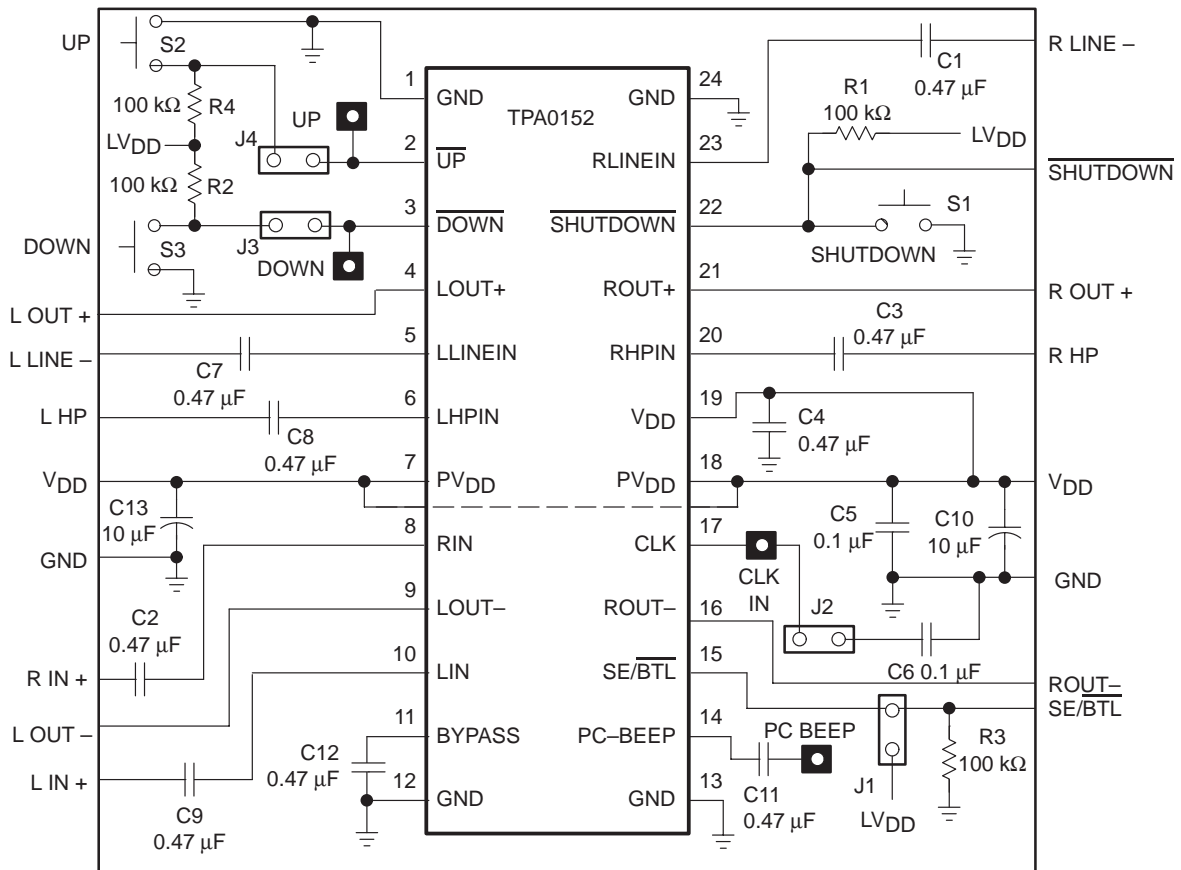

### 3.3.2.1 S1 — Shutdown Switch

Pushbutton switch S1 on the EVM allows the manual shutdown of the TPA0152 amplifier IC.

### 3.3.2.2 S2 and S3 – Volume Control Switches

Pushbuttons S2 (UP) and S3 (DOWN) allow for adjustment of the volume level.

### 3.3.2.3 J1 — Output Mode Jumper

To keep the module amplifier IC in the single-ended output mode regardless of the module control input state, set jumper J1 to ON.

Jumper J1 connects the  $\overline{\text{SE/BTL}}$  output mode control input pin on the amplifier IC directly to  $V_{\text{DD}}$ , so that when J1 is ON, the IC is held in the single-ended output mode regardless of the state of the  $\overline{\text{SE/BTL}}$  module control input. When J1 is OFF, a pulldown resistor on the module holds the IC output mode control input pin low, keeping the IC in the BTL output mode.

The TPA0152 amplifier IC has two separate inputs for each channel. An internal multiplexor selects which input will be connected to the amplifier based on the state of the  $\overline{\text{SE/BTL}}$  pin on the IC.

### 3.3.2.4 J2 – Microprocessor Mode Jumper

The TPA0152 operates with an internal clock running at a speed of 100 Hz that is used by the digital volume control when the jumper J2 is set to ON. However, the amplifier may be controlled by an external microprocessor clock at a speed of up to 45 kHz when the jumper J2 is set to OFF and the external clock signal line is connected to the CLK IN signal input pin. Note that the internal delay between volume level increments is disabled in microprocessor mode.

### 3.3.2.5 J3 and J4 – Volume Control Mode Jumpers

To control the volume with the S2 (UP) and S3 (DOWN) pushbuttons, leave jumpers J3 and J4 set to ON. If external control signals are to be used, set jumpers J3 and J4 to OFF and connect the control lines to the UP and DOWN signal input pins. When the desired line is pulled low for four clock cycles, the volume will increment by one step, followed by a short delay. This delay will decrease the longer the line is held low, eventually reaching a delay of zero.

### 3.3.2.6 PC BEEP Signal Input Pin

Leave PC BEEP signal input pin floating for normal operation.

The TPA0152 amplifier IC monitors this input for a signal when it is operating in both the active and shutdown modes. When a signal is detected, the IC automatically switches to this input and applies the signal to *both* channels. When the signal ends, the IC switches back to the line inputs. The gain of this input is approximately 1/4 V/V. See the TPA0152 amplifier data sheet for additional information.

### **3.3.2.7 UP and DOWN Signal Input Pins**

Leave the UP and DOWN signal input pins floating for normal operation.

If external control signals are to be used, set jumpers J3 and J4 to OFF and connect the control lines to the UP and DOWN signal input pins. When the desired line is pulled low for four clock cycles, the volume will increment by one step, followed by a short delay. This delay will decrease the longer the line is held low, eventually reaching a delay of zero.

### **3.3.2.8 CLK IN Signal Input Pin**

Leave the CLK IN signal input pin floating for normal operation.

The amplifier may be controlled by an external microprocessor clock at a speed of up to 45 kHz when the jumper J2 is set to OFF and the external clock signal line is connected to the CLK IN signal input pin. Note that the internal delay between volume level increments is disabled during microprocessor mode.

### 3.3.3 Signal Routing

Signal flow on the platform is controlled by two signal routing switches, as shown in Figure 3–6.

Figure 3–6. Platform Signal Routing and Outputs

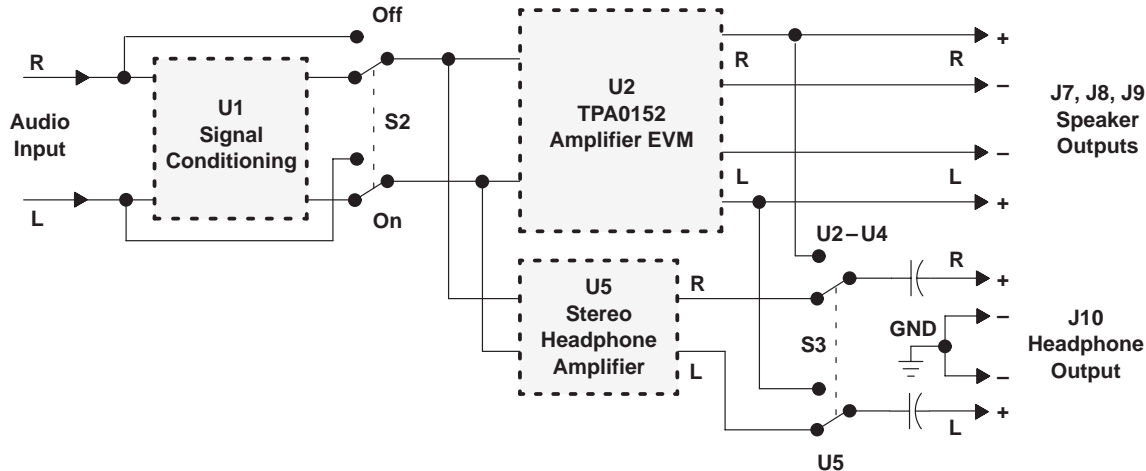

#### 3.3.3.1 Signal Conditioning

The audio signal from the input jacks can be applied to the signal conditioning socket (U1) if an EVM is installed there, or socket U1 can be bypassed and the audio input signal applied directly to the inputs of the TPA0152.

- Switch **S2** selects signal conditioning or bypasses it

#### 3.3.3.2 Headphone Output Jack

Switch S3 is the source select for the stereo headphone output jack, J10. The headphone jack is capacitively coupled (via 470  $\mu$ F electrolytics) and can output either the signal from the headphone amplifier in socket U5, or the signal from the TPA0152 power amplifier installed in socket U2, as determined by the setting of headphone source select switch S3.

When S3 is set to the power amplifier position (U2 – U4), the headphone jack is connected to the TPA0152 power amplifier OUT+ output lines. When a plug is inserted into the jack, signals output through J10 are returned to platform ground, requiring single-ended power amplifier operation. A switch inside the headphone jack produces a control signal that can be routed to the power amplifier socket to shut down the TPA0152 EVM or switch it to single-ended output mode when a plug is inserted.

Source select switch S3 connects the headphone jack to the output lines of either the headphone amplifier socket U5, or the power amplifier sockets (U2 – U4).

- To keep the TPA0152 amplifier outputs separated, set switch **S3** to the headphone amplifier position (**U5**) and use the speaker outputs (**J7**, **J8**, and **J9**)
- To route the TPA0152 amplifier outputs to the headphone output jack (**J10**), set switch **S3** to the power amplifier position (**U2 – U4**) — use this setting *only* if the TPA0152 EVM is to drive single-ended loads connected to **J10**

### 3.3.4 Mute (Shutdown)/Mode

The TPA0152 EVM is equipped with a shutdown control input pin. When this input is pulled to ground, the TPA0152 amplifier IC on the module enters the shutdown mode and dissipates very little power. While in the shutdown mode, the PC BEEP input is still active. When the EVM control input is tied to GND or allowed to float, normal amplifier operation resumes.

In typical applications, as often found in notebook computers, portable audio products, and such, the internal speakers mute when headphones are plugged into the headphone jack, or internal speakers mute when external speakers are connected. In applications using separate speaker and headphone amplifiers, the one not being used can be shut down to conserve power.

A mode control input pin on the EVM switches the TPA0152 amplifier IC between the bridge-tied load (BTL) output mode and the single-ended (SE) output mode. When the mode control input is tied to GND, the module operates in the BTL output mode. When this input is tied to  $V_{DD}$ , the module operates in the single-ended output mode.

In the typical application, output mode switching allows the TPA0152 to operate in the BTL output mode for increased power to internal speakers and then switch to single-ended mode to drive headphones when a plug is inserted into the headphone jack.

#### 3.3.4.1 Headphone Jack Control Signals

The platform headphone output jack (J10) contains an internal switch that changes the state of a pair of control lines when a plug is inserted (Figure 3–7). Each control line is pulled down by a 1-k $\Omega$  resistor to ground (R4 and R5). The switch in the headphone jack pulls one line or the other up to  $V_{DD}$  through a 240- $\Omega$  resistor (R3) depending on whether a plug is inserted in J10 or not.

Figure 3–7. Mute/Mode and Polarity Control

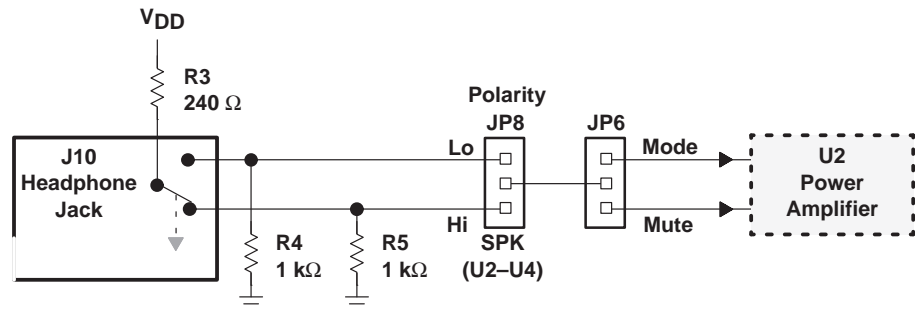

### 3.3.4.2 Mute/Mode Select (JP6)

A 3-pin jumper header (JP6) on the platform, functioning as an SPDT switch, routes the control signal from the headphone jack to either the shutdown control input pin or the mode control input pin of the evaluation module.

- To shut down the TPA0152 amplifier module using the control signal from the platform headphone jack, jumper **JP6** to **MUTE**.
- To switch the output mode of the TPA0152 amplifier between BTL and single-ended using the control signal from the platform headphone jack, jumper **JP6** to **MODE**.

### 3.3.4.3 Mute/Mode Polarity Select (JP8)

A second 3-pin jumper header (JP8) on the platform selects the control signal polarity by connecting either the active-high or the active-low line from the headphone jack to jumper JP6.

- When JP6 is set to Mute, use the following JP8 settings for the TPA0152:
  - To shut down the TPA0152 amplifier module *when* a plug is inserted into the headphone jack, jumper **JP8** to **Lo** (this is the typical setting).
  - To shut down the TPA0152 amplifier module *until* a plug is inserted into the headphone jack, jumper **JP8** to **Hi**.
- When JP6 is set to Mode, use the following JP8 settings for the TPA0152:
  - To switch the TPA0152 amplifier module to the *single-ended* output mode when a plug is inserted into the headphone jack, jumper **JP8** to **Hi** (this is the typical setting).
  - To switch the TPA0152 amplifier module to the *BTL* output mode when a plug is inserted into the headphone jack, jumper **JP8** to **Lo**.

### 3.3.5 Power Requirements

The TPA0152 audio power amplifier evaluation module can operate from any voltage between approximately 4.5 V and 5.5 V; however, the TPA0152 amplifier IC on the module is characterized for operation at 5 V. For best performance (highest output power with lowest distortion), the module should be operated at approximately 5 V unless there is a specific reason for operating it from a different voltage.

The TI plug-n-play audio amplifier evaluation platform with a voltage regulator EVM installed on it can provide a regulated  $V_{DD}$  supply from a wide variety of unregulated  $V_{CC}$  voltage inputs between approximately 5.5 V and 12 V, including an onboard 9-V battery. Or, an external regulated power source can be used to supply  $V_{DD}$  voltage to the platform and the TPA0152 evaluation module installed on it.

Although the TPA0152 amplifier IC draws approximately 0.65 A from the power supply during continuous full power output, peak current draw can be as high as 1 A. Any power supply connected to the platform should be capable of providing 1 A of current to avoid clipping of the output signal during peaks. Current consumption driving speakers at normal listening levels is typically 0.3 A or less.

The platform is equipped with overvoltage and reverse-polarity supply voltage input protection in the form of fused crowbar circuits.

- $V_{DD}$  voltage applied to platform screw terminals J6 *MUST NOT* exceed the absolute maximum rating for the TPA0152 amplifier IC installed on the evaluation module (6 V) or damage to the IC may result. In no case should  $V_{DD}$  voltage of the incorrect polarity or in excess of 6.1 V be applied to screw terminals J6 of the platform, or the power protection circuit on the  $V_{DD}$  line will trip.
- $V_{CC}$  voltage applied to the platform *MUST NOT* exceed the maximum voltage input specified for the voltage regulator module installed in socket U6 (12 V for the SLVP097), or damage to the voltage regulator module may result. In no case should  $V_{CC}$  voltage applied to the platform exceed 15 V, or the overvoltage protection circuit on the  $V_{CC}$  bus will trip.

### 3.3.6 Inputs and Outputs

The TI plug-n-play audio amplifier evaluation platform is equipped with several standard connectors for audio inputs and outputs.

#### 3.3.6.1 Inputs

In most cases, audio signals enter the platform through either a pair of RCA phono jacks (J3 and J5) or a miniature (1/8") stereo phone jack (J4). Certain signal conditioning and amplifier EVMs, however, may have additional signal input connectors mounted on the module circuit board. The TPA0152 EVM has a special PC BEEP signal input pin on the top of the module PCB.

The platform audio signal input jacks (J3, J4, and J5) are of the closed-circuit type, grounding the signal input lines when no plugs are inserted.

#### 3.3.6.2 Outputs

Amplified audio output signals leave the platform through left and right RCA phono jacks (J7 and J9), left and right pairs of compression connectors for stripped speaker wires (J8), and optionally, through a miniature (1/8") stereo phone jack (J10), for headphones.

The audio output lines from the power amplifiers are separate all the way to the edge of the platform (output jacks J7, J8, and J9) — the OUT– lines from the power amplifier sockets are not tied to each other or to platform ground. This allows the TPA0152 power amplifier EVM to operate in the highly-efficient bridge-tied load configuration when driving speakers.

The headphone jack (J10) is capacitively coupled to source select switch S3, which connects J10 to the output lines of either the headphone amplifier socket or the power amplifier sockets (Figure 3–6). When the TPA0152 output signal is routed to J10 by S3, signals output via J10 are returned to platform ground when a plug is inserted (Figure 3–8), requiring single-ended operation of the power amplifiers.

Figure 3–8. Typical Headphone Plug

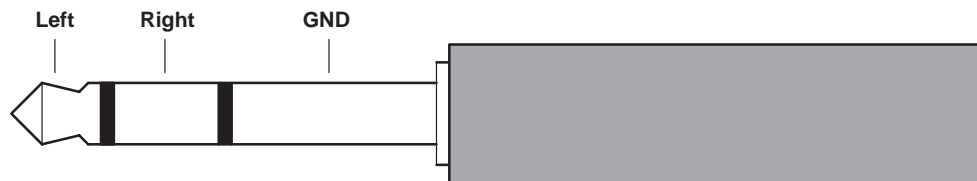



### 3.4 Using The TPA0152 EVM Stand-Alone

Using the TPA0152 audio power amplifier evaluation module stand-alone is much the same as using it with the platform. The same 4.5-V to 5.5-V power supply range and the isolated OUT+ and OUT- lines for BTL operation requirement exists.

Note that the shutdown signal applied to the EVM  $\overline{\text{SHUTDOWN}}$  pin must be able to supply enough current to overcome the pullup resistor on the module (100 k $\Omega$ ).

#### 3.4.1 TPA0152 EVM Connected for BTL Output

Figure 3–9. TPA0152 EVM Connected for Stereo BTL Output

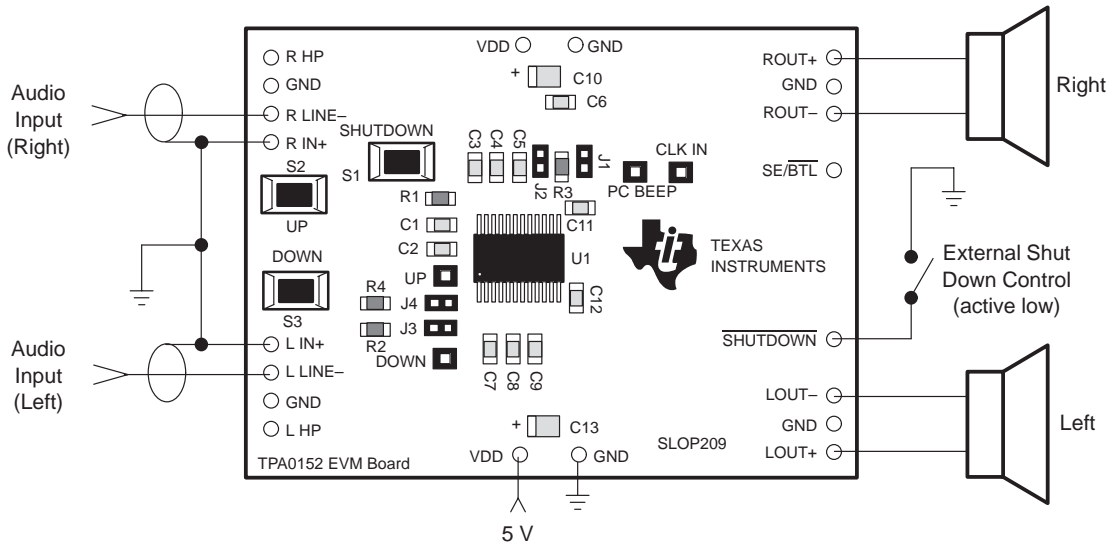

Table 3–2. Typical TPA0152 EVM Jumper Settings for BTL Stand-Alone

EVM	J1	J2	J3	J4
TPA0152	OFF	ON	ON	ON

Note: ON = Shunt installed, OFF = Open

### 3.4.2 TPA0152 EVM Connected for Single-Ended Output

Figure 3–10. TPA0152 EVM Connected for Stereo Single-Ended Output

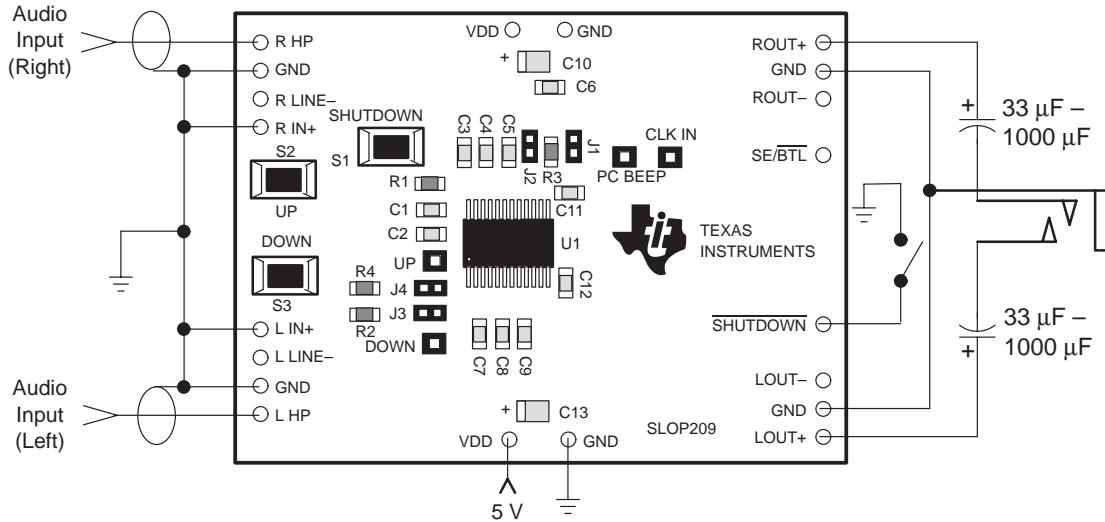

Table 3–3. Typical TPA0152 EVM Jumper Settings for Single-Ended Stand-Alone

EVM	J1	J2	J3	J4
TPA0152	ON	ON	ON	ON

**Note:** ON = Shunt installed, OFF = Open

### 3.5 TPA0152 Audio Power Amplifier Evaluation Module Parts List

Table 3–4. TPA0152 EVM Parts List

Ref.	Description	Size	EVM Qty.	Manufacturer/ Part Number	Digi-Key Number
C5	Capacitor, 0.1 $\mu$ F, 10%, nonpolarized	0805	1	Murata GRM40-X7R104K25	
C1, C2, C3, C4, C7, C8, C9, C11, C12	Capacitor, 0.47 $\mu$ F, 80%/–20%, nonpolarized	0805	9	Murata GRM40-Y5V474Z16	
C6	Capacitor, 0.47 nF, 80%/–20%, nonpolarized	0805	1		
C10, C13	Capacitor, 10 $\mu$ F, 6.3 V	A	2	Panasonic ECS-TOJY106R	Digi-Key PCS1106CT-ND
R1, R2, R3, R4	Resistor, 100 k $\Omega$ , 1/8 W, 5%	0805	4	Panasonic ERJ-6GEYJ104V	Digi-Key P100KABK-ND
S1, S2, S3	Switch, momentary	SMD	3	Panasonic P8050SCT-ND	Digi-Key P8050SCT-ND
UP, DOWN, CLK IN, PC BEEP	Test points, red		4	Farnell 240–345	
J1, J2, J3, J4	Header, 2 position	2 mm	4	Norcomp	Digi-Key 2163S-02-ND
P1, P2, P3, P4, P5	Shunts	2 mm	5	2JM–G	Digi-Key SPE1302–ND
	Terminal posts		20	Sullins PTC36SABN	Digi-Key S1022–36–ND
U1	IC, TPA0152, audio amplifier, 1 W, 2 channel	24 pin TSSOP	1	TI TPA0152PWP	
PCB1	PCB, TPA0152 EVM		1	TI SLOP209	

